

SPACE

EXTRACTORES DE BANHO ULTRA-SILENCIOSOS COM DESENHO AERODINÂMICO

- Desenho estético e moderno,
- Integração arquitectónica com os elementos de uma casa de banho,
- Ultra-silencioso,
- Alto rendimento graças ao desenho aerodinâmico que facilita a entrada do fluxo de ar,
- Montagem rápida sem ferramentas.

Modelo	mm		
SPACE-80	90	BASIC	600SP080B000
SPACE-100	100	BASIC	600SP100B000
SPACE-100-T	100	TIMER	600SP100TB00
SPACE-120	120	BASIC	600SP120B000
SPACE-120-T	120	TIMER	600SP120TB00
SPACE-150	150	BASIC	600SP150B000
SPACE-150-T	150	TIMER	600SP150TB00

DADOS TÉCNICOS

Modelo	230V 50Hz		m ³ /h	mmH ₂ O	db(A)	Kg
	r/min	W				
SPACE-80	2500	15	70	3	38	0,57
SPACE-100	2500	15	98	3	39	0,60
SPACE-120	2450	20	190	5	41	0,80
SPACE-150	2100	25	320	8	43	0,90



DIMENSÕES

Modelo	A	B	C	D
SPACE-80	86	140	88	10
SPACE-100	98	140	98	10
SPACE-120	118	170	100	13
SPACE-150	148	190	112	15

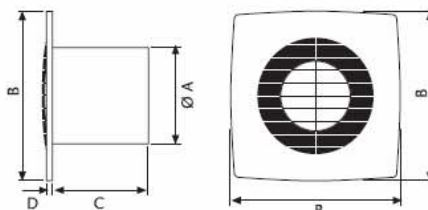

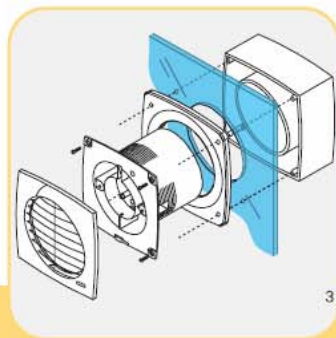
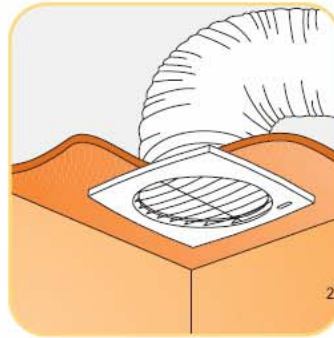
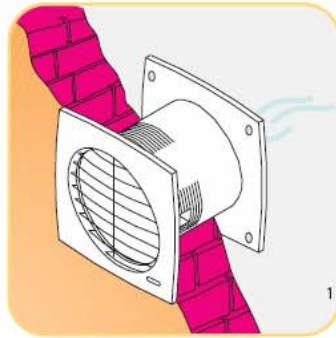

- 1 – Instalação integrada na parede
- 2 – Instalação integrada no tecto
- 3 – Instalação encastrada na janela
- 4 – Sistema exclusivo de fixação rápida sem parafusos

CONSTRUÇÃO

- Acabamentos em branco,
- Sistema de fixação sem parafusos, excepto modelo 80,
- Comporta anti-retorno de série em todos os modelos, excepto modelo 80,
- Luz de aviso para indicar o funcionamento, no modelo 150,
- Preparado para intercalar em janela, com os seus acessórios correspondentes,
- Motor 230V 50 Hz

VERSÕES

- BASIC: funciona com o interruptor da luz ou independente,
- TIMER: funciona com temporizador electrónico regulável.

CURVA CARACTERÍSTICA

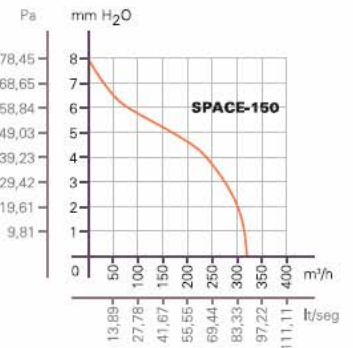
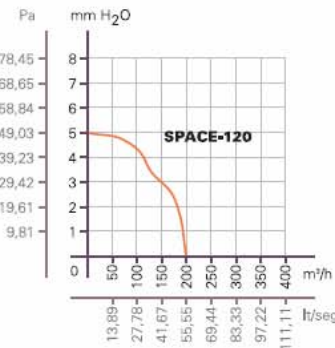
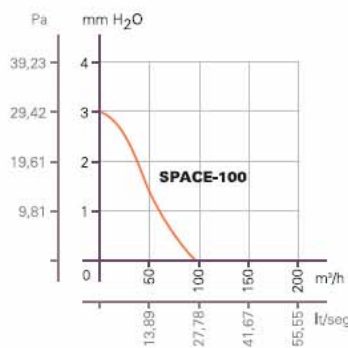
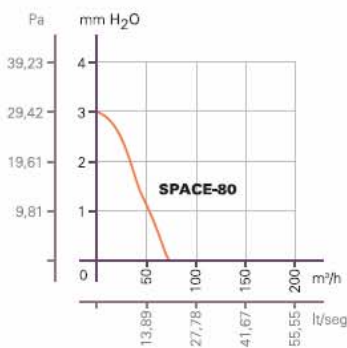

ACESSÓRIOS



Grelha decorativa



Persiana de sobrepressão



Kit Cristal



Aro de fixação Cristal



Regulador de velocidade