

# Cleaning Accessories $\varnothing$ 76

**Part No Description**

- 7126 Handle for suction lance
- 7127 Scraper for suction lance
- 7129 Handle complete
- 7161 Bulk nozzle 76
- 7162 Suction lance 76

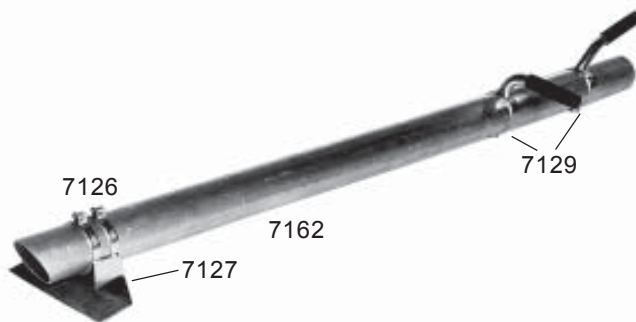

**Pressure Loss**

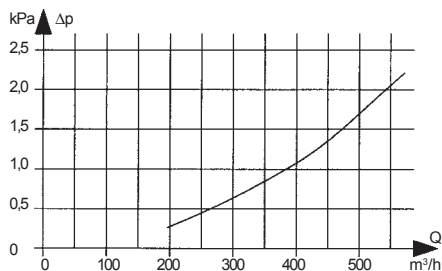

Pressure loss curve is valid for clean air. note that transported material will increase pressure loss according to the calculation on p. 6.

# Welding Accessories/suction nozzles



**Part No Description**

- 4149 Suction nozzle
- 6005 Universal nozzle
- 6098 Tubular nozzle
- 6610 Universal nozzle
- 7148 Funnel shaped nozzle  $\varnothing$  50
- 7150 Magnetic holder for 7148, 4149

**Connection ( $\varnothing$ )**

- 50
- 38
- 38
- 38
- 50
- 50

TECHNICAL DATA		
Part No	Q <sub>nom</sub>	$\Delta p_{nom}$
4149	250 m³/h	1.6 kPa
6005	150 m³/h	1.6 kPa
6098	150 m³/h	3.8 kPa
6010	150 m³/h	1.6 kPa
7148	250 m³/h	1.6 kPa
9060	150 m³/h	2.7 kPa